



Contactor relay,3M/10e,AC-operated



Powering Business Worldwide™

Part no. DILA-31(110V50/60HZ)

Article no. 276370

Delivery programme

Product range			DILA relays
Application			Contactor relays
Description			Basic devices with positive operation contacts
Connection technique			Screw terminals
Rated operational current			
AC-15			
220 V 230 V 240 V	I_e	A	4
380 V 400 V 415 V	I_e	A	4
Contacts			
N/O = Normally open			3 M
N/C = Normally closed			1 N/C
Contact sequence			
Code number and version of combination			
Distinctive number			31E
Can be combined with auxiliary contact module			DILA-XHI(V)...
Actuating voltage			110 V 50/60 Hz
Voltage AC/DC			AC operation
Instructions			Contact numbers to EN 50011 Coil terminal markings to EN 50005

Approvals

Product Standards	IEC/EN 60947-4-1; UL 508; CSA-C22.2 No. 14-05; CE marking
UL File No.	E29184
UL CCN	NKCR
CSA File No.	012528
CSA Class No.	3211-03
NA Certification	UL listed, CSA certified
Specially designed for NA	No

General

Standards			IEC/EN 60947, VDE 0660, UL, CSA
Lifespan, mechanical			
AC operated	Operations	$x 10^6$	20
DC operated	Operations	$x 10^6$	20
Maximum operating frequency		Ops./h	
Maximum operating frequency		Operations/h	9000
Climatic proofing			Damp heat, constant to IEC 60068-2-78 Damp heat, cyclic to IEC 60068-2-30
Ambient temperature		°C	
Open		°C	- 25 - 60
Enclosed		°C	- 25 - 40
Ambient temperature, storage		°C	- 40 - 80
Mounting position			

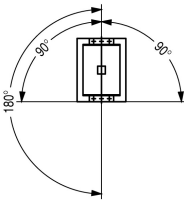
Mounting position			
Mechanical shock resistance (IEC/EN 60068-2-27)			
Half-sinusoidal shock, 10 ms			
Basic unit with auxiliary contact module		g	
N/O contact		g	7
N/C contact		g	5
Protection type			IP20
Protection against direct contact when actuated from front (EN 50274)			Finger and back-of-hand proof
Weight			
AC operated		kg	0.23
DC operated		kg	0.28
Terminal capacities		mm ²	
Screw terminals			
Solid		mm ²	1 x (0,75 - 4) 2 x (0,75 - 2,5)
Flexible with ferrule		mm ²	1 x (0,75 - 2,5) 2 x (0,75 - 2,5)
Solid or stranded		AWG	18 - 14
Terminal screw			M3.5
Pozidriv screwdriver		Size	2
Standard screwdriver		mm	0.8 x 5.5 1 x 6
Max. tightening torque		Nm	1.2
Spring-loaded terminals			
Solid		mm ²	1 x (0,75 - 2,5) 2 x (0,75 - 2,5)
Flexible with or without ferrule DIN 46228		mm ²	1 x (0,75 - 1,5) 2 x (0,75 - 1,5)
Solid or stranded		AWG	18 - 14
Standard screwdriver		mm	0.6 x 3.5

Contacts

Positive operating contacts to ZH 1/457, including auxiliary contact module			Yes
Rated impulse withstand voltage	U_{imp}	V AC	6000
Overvoltage category/pollution degree			III/3
Rated insulation voltage	U_i	V AC	690
Rated operational voltage	U_e	V AC	690
Rated operational current		A	
Conventional free air thermal current, 3 pole, 50 - 60 Hz			
Open			
Conv. thermal current	I_{th}	A	16
AC-15			
220 V 230 V 240 V	I_e	A	4
380 V 400 V 415 V	I_e	A	4
500 V	I_e	A	1.5
DC current			
DC-13 L/R - 15 ms			
Contacts in series:		A	
1	24 V	A	10
1	60 V	A	6
2	60 V	A	10

1	110 V	A	3
3	110 V	A	6
1	220 V	A	1
3	220 V	A	5
DC-13 L/R - 50 ms			
Contacts in series:		A	
3	24 V	A	4
3	60 V	A	4
3	110 V	A	2
3	220 V	A	1
Safe isolation to VDE 0106 Part 101 and Part 101/A1			
between coil and auxiliary contacts		V AC	400
between the auxiliary contacts		V AC	400
Conv. thermal current	I_{th}	A	16
Control circuit reliability	Failure rate	λ	$<10^{-8}$, < one failure at 100 million operations (at $U_g = 24$ V DC, $U_{min} = 17$ V, $I_{min} = 5.4$ mA)
Conv. thermal current	I_{th}	A	16
Short-circuit rating without welding			
Maximum overcurrent protective device			
220/240 V		PKZM0	4
380/415 V		PKZM0	4
Short-circuit protection maximum fuse			
500 V		A gG/ gL	10
Current heat loss at I_{th}			
AC operated		W	0.3
DC operated		W	0.3
Magnet systems			
Voltage tolerance		$x U_c$	
AC operated		$x U_c$	
		Pick-up	$x U_c$
DC operated		$x U_c$	0.8 - 1.1
		Pick-up	$x U_c$
at 24 V: without auxiliary contact component (40 °C)		Pick-up	$x U_c$
			0.7 - 1.3
Power consumption			
50 Hz		Pick-up	VA
			24
50 Hz		Sealing	VA
			3.4
50 Hz		Sealing	W
			1.2
60 Hz		Pick-up	VA
			30
60 Hz		Sealing	VA
			4.4
60 Hz		Sealing	W
			1.4
50/60 Hz		Pick-up	VA
			27 25
50/60 Hz		Sealing	VA
			4.2 3.3
50/60 Hz		Sealing	W
			1.4 1.2
DC operated		Pull-in = sealing	W
			3
Duty factor		% DF	100
Switching times at 100 % U_c (approximate values)			
AC operated closing delay		ms	15 - 21
AC operated N/O contact opening delay		ms	9 - 18
DC operated closing delay		ms	

Switching times, DC operated, max. closing delay	ms	31
DC operated N/O contact opening delay	ms	
Switching times, DC actuated make contact Opening delay, max.	ms	12

Notes

Notes Making and breaking conditions to DC-13, time constant as stated
 See transparent overlay "Fuses" for time/current characteristics (please enquire)
 Use only equal cross-sections

Technical data ETIM 4.0

Connection type main circuit			Screw connection
Rated control voltage Us at DC		V	0
Rated control voltage Us at AC 60HZ		V	110
Rated control voltage Us at AC 50HZ		V	110
Number of auxiliary contacts as changeover contacts			0
Rated operation current Ie , 400 V		A	4
Number of auxiliary contacts as N/Cs			1
Number of auxiliary contacts as N/Os			3
Voltage type for actuation			AC
Number of auxiliary contacts as N/Os, leading			0
Number of auxiliary contacts as N/Cs, delayed switching			0

Characteristics

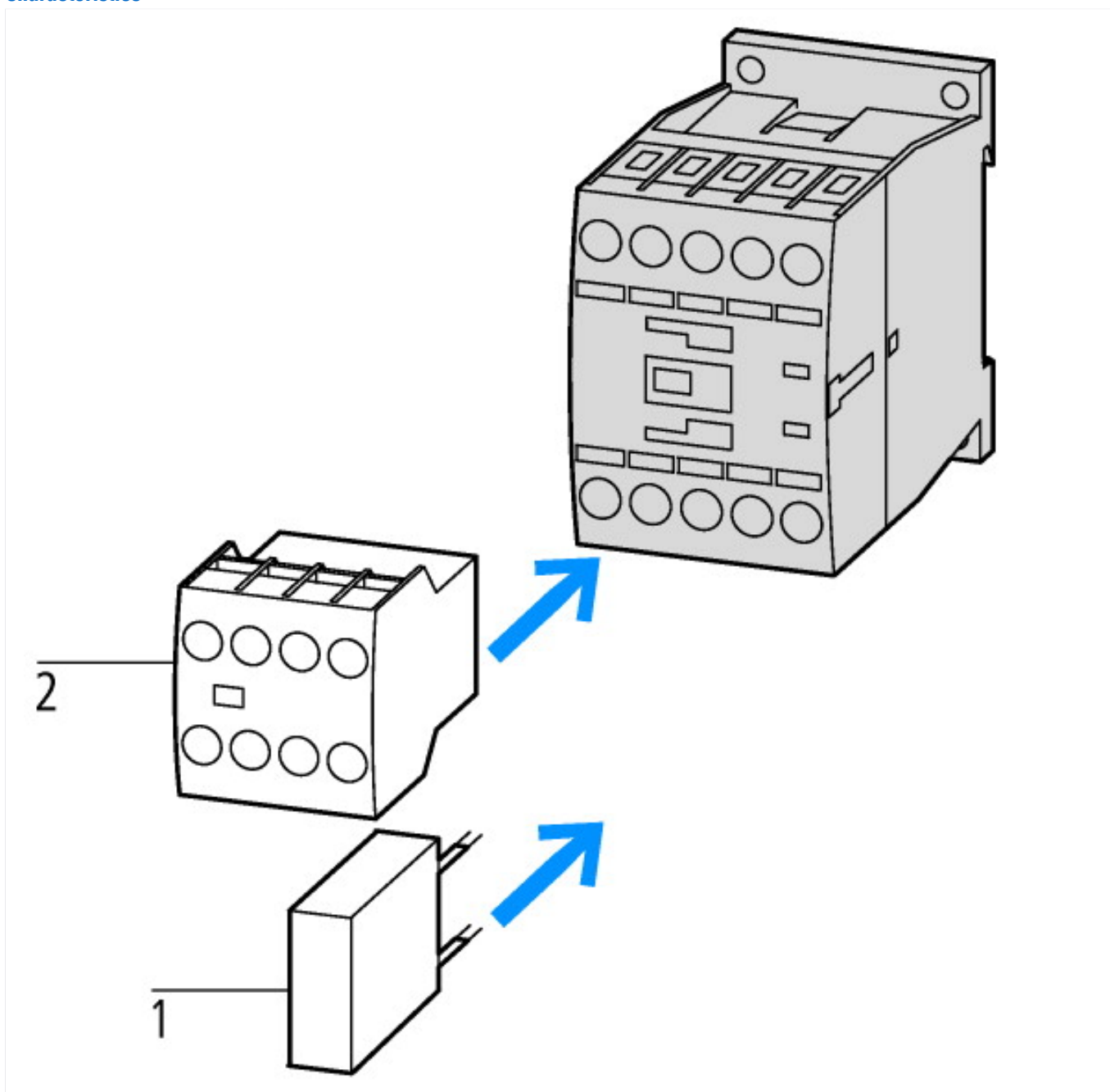

- 1: Suppressor
- 2: Auxiliary contact module

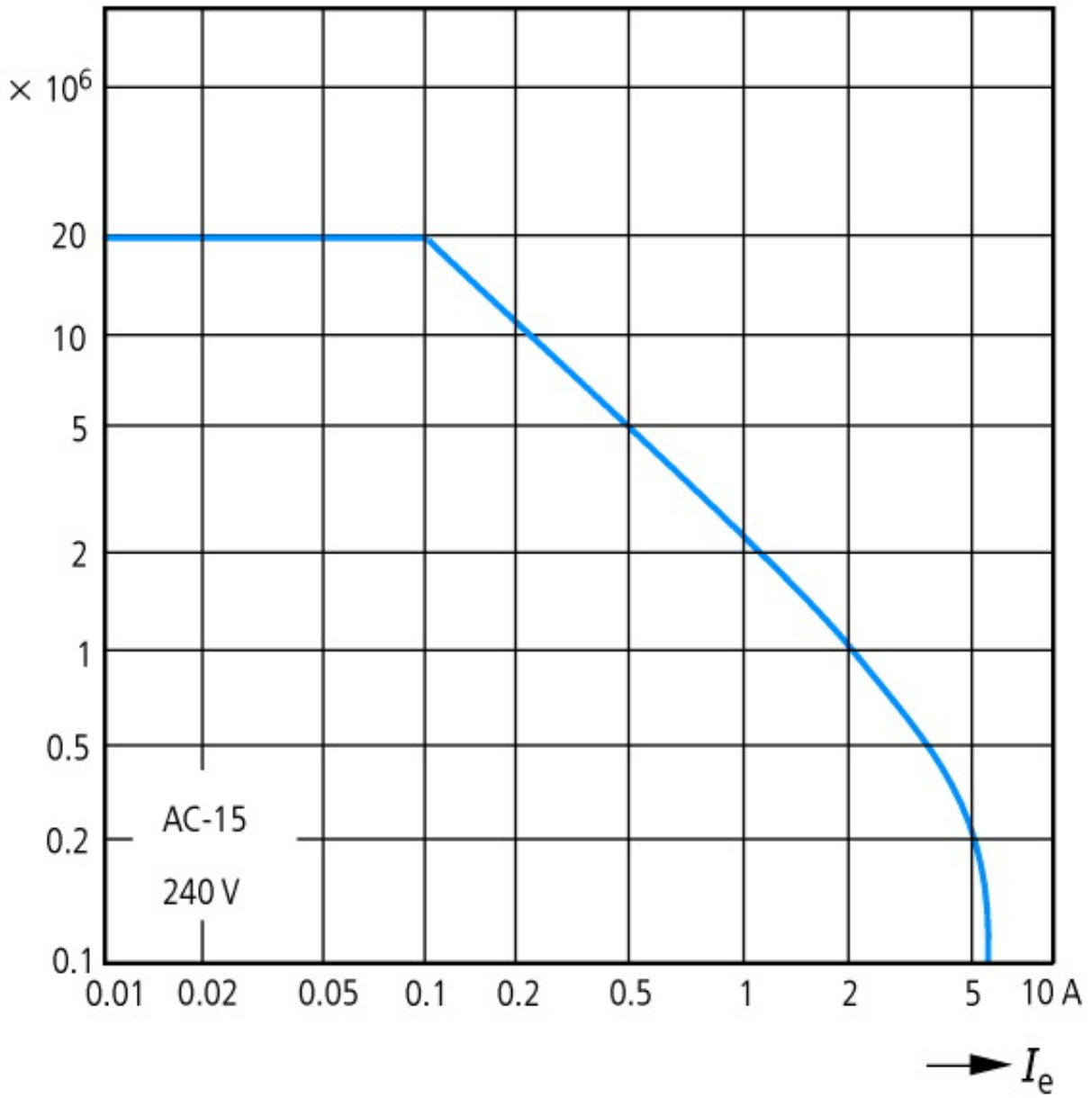

Component lifespan (operations)
 I_e = Rated operational current

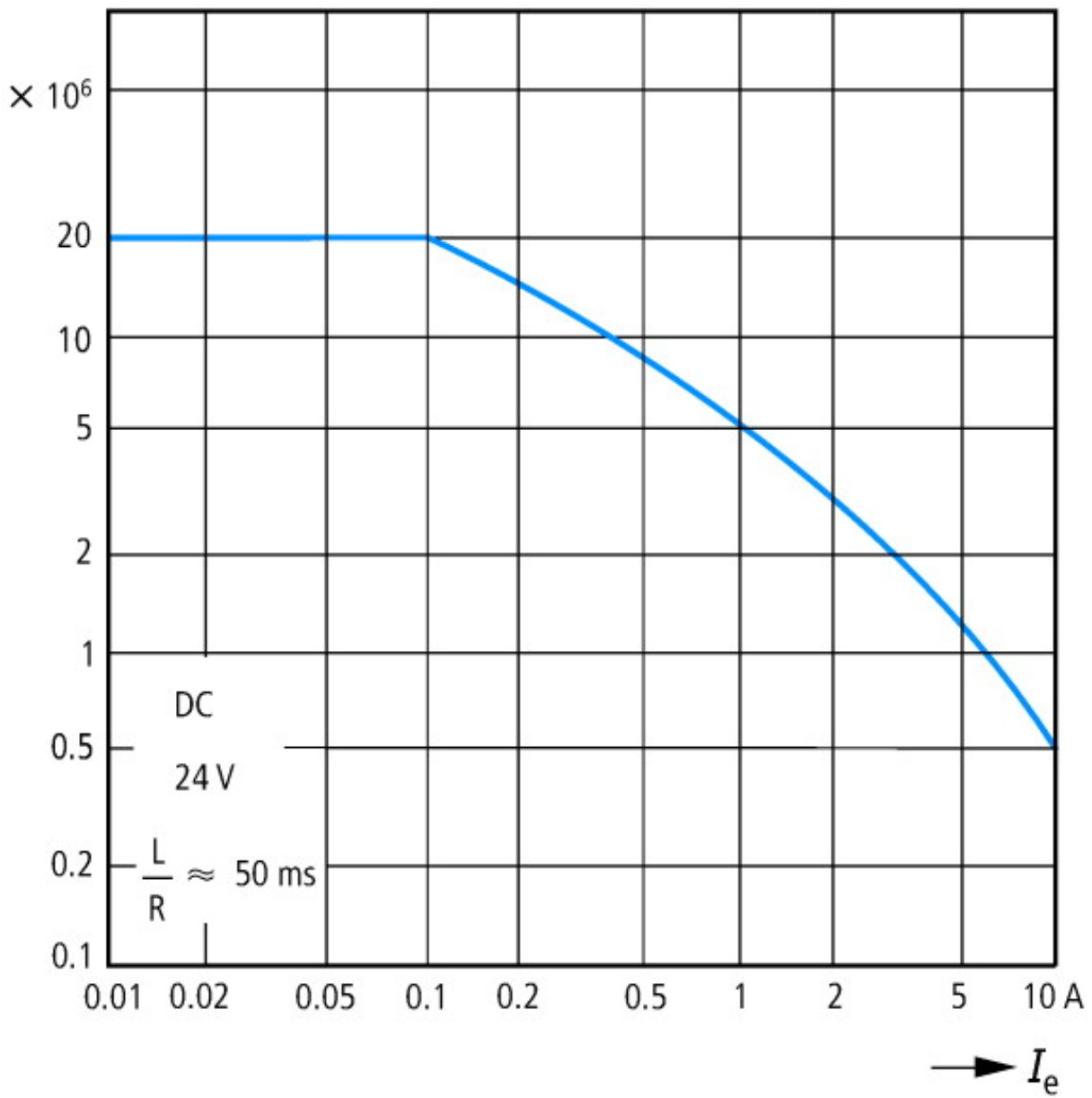

Component lifespan (operations)
 I_e = Rated operational current

Dimensions

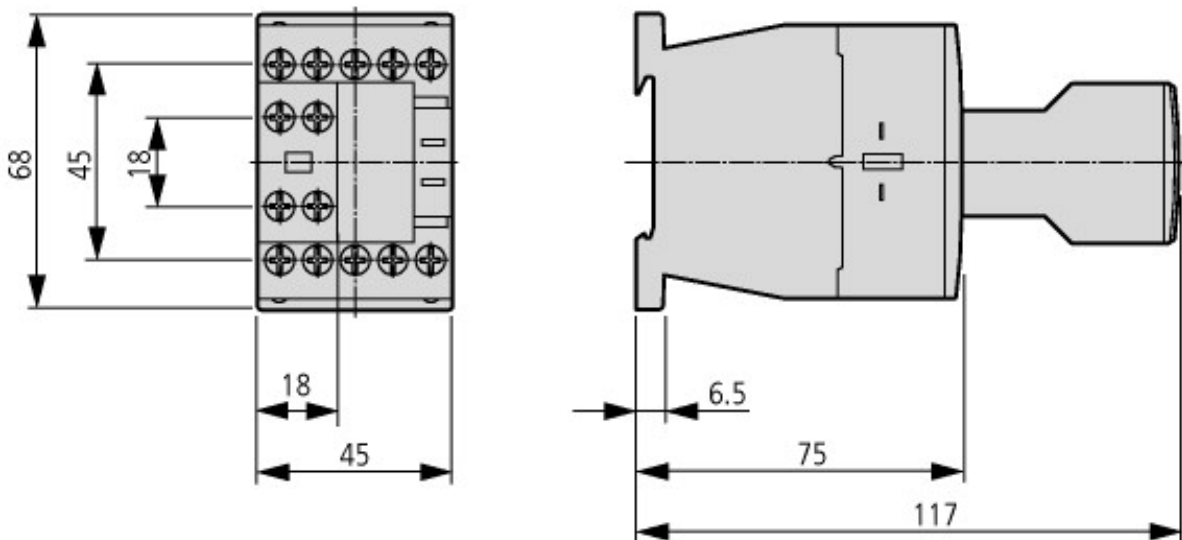

Contactor with auxiliary contact module

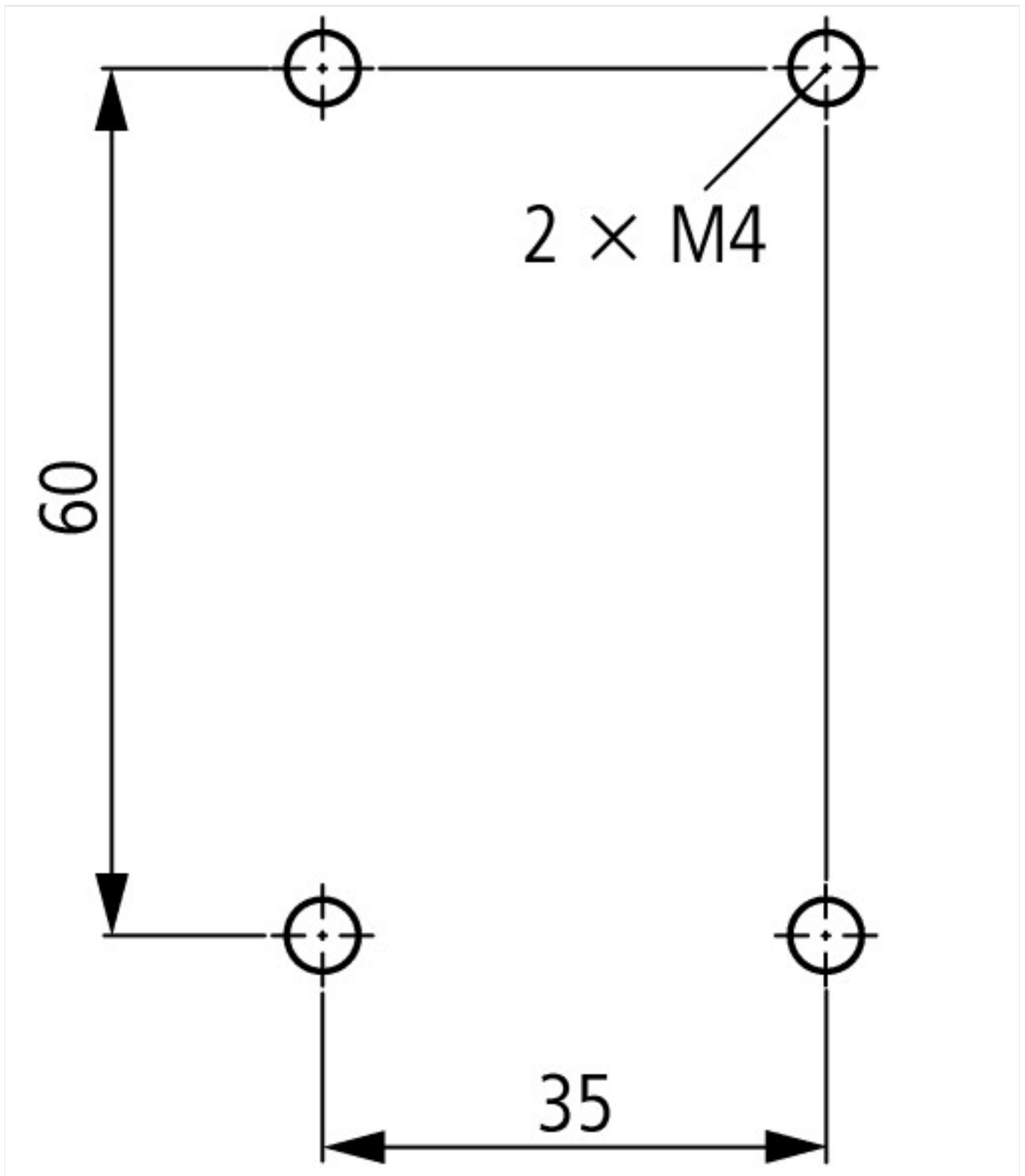

Additional product information (links)

IL03407013Z (AWA2100-2126) Contactors

IL03407013Z (AWA2100-2126)
Contactors

ftp://ftp.moeller.net/DOCUMENTATION/AWA_INSTRUCTIONS/IL03407013Z2012_03.pdf

<http://de.ecat.moeller.net/flip-cat/?edition=HPLTE&startpage=5.84>